



A CRANE CO. COMPANY

MFLHP SERIES DC/DC CONVERTERS

North America: Tel. (800) 822-8782, (425) 882-3100 Fax (425) 882-1990

International: Tel. +44-1252-815511 Fax +44-1252-815577

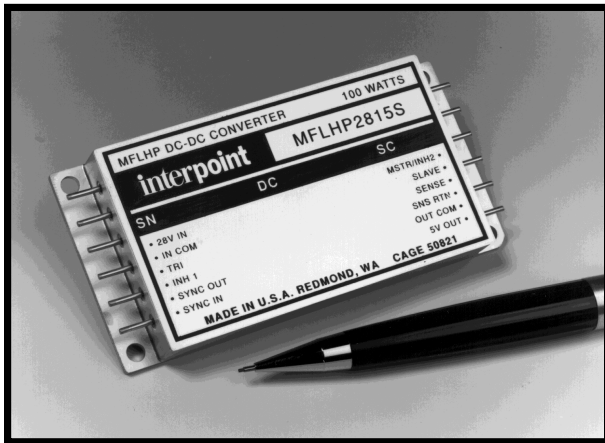

- Up to 100 watts output power
- 19 to 40 Vdc input
- Parallelable for up to 270 watts
- 100° C full power operation
- 0.40 inch height
- Single or dual outputs, ± 5 , ± 12 , ± 15 Vdc
- Current limiting short circuit protection
- Low voltage lockout
- Compatible with MIL-STD-704A-D power bus standards

The MFLHP Series™ 28-volt dc-dc converters are rated up to 100 watts output power over a -55° to +100°C temperature range with a 28 Vdc nominal input. On dual output models, up to 70% of the rated output power can be drawn from either the positive or negative outputs. Current sharing allows the units to be paralleled for total power of up to 270 watts. The welded, hermetically sealed package is only 3.0 x 1.5 x 0.40 inches, giving the series an overall power density of up to 70 watts per cubic inch.

DESIGN FEATURES

The MFLHP Series converters are switching regulators that use a quasi-square wave, single ended forward converter design with a constant switching frequency of 600 kHz.

Isolation between input and output circuits is provided with a transformer in the forward path and wide bandwidth magnetic coupling in the feedback control loop. The MFLHP uses a unique dual loop feedback technique that controls output current with an inner feedback loop and output voltage with a cascaded voltage mode feedback loop.

The additional secondary current mode feedback loop improves transient response in a manner similar to primary current mode control and allows for ease of paralleling.

Tight load regulation is achieved through a wide-bandwidth magnetic feedback circuit. The output voltage on single MFLHP models can be easily trimmed by adding an external resistor. (See Figure A for voltage changes with different resistor values.)

INHIBIT

The MFLHP Series converters have two TTL compatible inhibit terminals (INH1 and INH2) that can be used to disable power conversion, resulting in a very low quiescent input current. An open collector TTL compatible low (<0.8 volts) is required between INH1 (pin 4) and Input Common (pin 2) to inhibit the converter. An open collector TTL compatible low (<0.5 volts) is required between INH2 (pin 12) and Output Common (pin 8) to inhibit the application of intermediate voltages to these pins (1.5 to 10.5 volts) should be avoided.

CURRENT SHARING AND PARALLEL OPERATION

Multiple MFLHPs may be used in parallel to drive a common load (see Figure B). In this mode of operation the load current is shared by two or three MFLHPs. In current sharing mode, one MFLHP is designated as a master. The SLAVE pin (pin 11) of the master is left unconnected and the MSTR/INH2 pin (pin 12) of the master is connected to the SLAVE pin (pin 11) of the slave units. The units designated as slaves have the MSTR/INH2 pin (pin 12) connected to the SNS RTN pin (pin 9). Figure B shows the typical setup for two or three units in parallel. Note that synchronizing the units together (though shown in the figure) is not required for current sharing operation. A second slave unit may be placed in parallel with a master and slave; this requires the TRI pin (pin 3) of the master unit to be connected to the SNS RTN pin (pin 9).

When paralleled, 90% of the total combined power ratings of the MFLHP are available at the load. Overload and short circuit performance are not adversely affected during parallel operation.

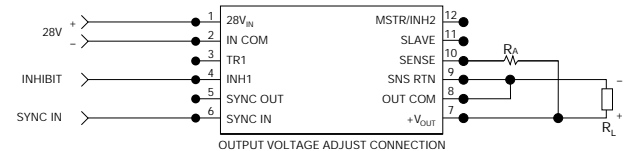
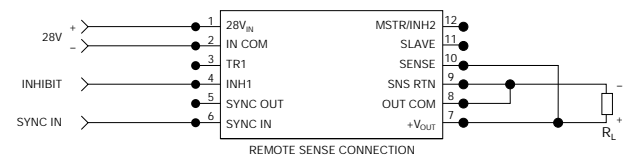

V _{out} INCREASE (VOLT)	R _A (OHMS)		
	5-V	12-V	15-V
0.1	70	25	20
0.2	140	50	40
0.3	210	75	60
0.4	280	100	80
0.5	350	125	100

REMOTE SENSE AND OUTPUT VOLTAGE ADJUSTMENT (APPLICABLE TO SINGLE OUTPUT MODELS ONLY)

Figure A

CRANE**interpoint**

A CRANE CO. COMPANY

**MFLHP SERIES
DC/DC CONVERTERS**

North America: Tel. (800) 822-8782, (425) 882-3100 Fax (425) 882-1990

International: Tel. +44-1252-815511 Fax +44-1252-815577

CHARACTERISTICS (ALL MODELS): T = 25°C, V_{IN} = 28 Vdc unless otherwise specified.

OPERATING TEMPERATURE RANGE:

Full Power: -55°C to +100°C (case)

Absolute: -55°C to +135°C (case)

STORAGE TEMPERATURE RANGE: -65°C to +150°C (case)

OUTPUT VOLTAGE TEMPERATURE COEFFICIENT:

0.01%/°C (typical)

TEMPERATURE RISE (STILL AIR): 10°C/W dissipated (typ)

ISOLATION: 100 megohm minimum at 500 Vdc

INPUT TO OUTPUT CAPACITANCE: 150 pF (typical)

AUDIO REJECTION: 50 dB (typical)

WEIGHT: 100 grams (max.)

CONVERSION FREQUENCY

Free run mode: 550 kHz min., 600 typ., 650 max.

Synchronized mode: 525 kHz min. to 675 kHz max.

SYNCHRONIZATION

Duty cycle: 40% min., 60% max.

Logic low = 0.8V max.

Logic high = 4.5V min.

OUTPUT INHIBIT PINS: TTL Open collector compatible

TTL logic high = output enabled

TTL logic low = output disabled

Open circuit voltage = 9-12 Vdc for INH1; 6-9 Vdc for INH2

Logic low current = -10 mA (max.) for INH1; -5 mA (max.) for INH2

Logic low voltage level = 0.8V (max.) for INH1; 0.5V (max.) for INH2

MEAN TIME BETWEEN FAILURES: 200,000 hrs. (AIT, 85°C)

PARAMETER	CONDITION	MFLHP2805S			MFLHP2812S			MFLHP2815S			UNITS
		MIN	TYP	MAX	MIN	TYP	MAX	MIN	TYP	MAX	
INPUT VOLTAGE	T _c = -55°C to +100°C NO LOAD TO FULL NORMAL TRANSIENT ¹	19	28	40	19	28	40	19	28	40	Vdc
INPUT CURRENT	T _c = -55°C to +100°C NO LOAD	—	70	120	—	50	80	—	50	80	mA
	FULL LOAD	—	3571	—	—	3782	—	—	4153	—	
	INHIBIT PIN 4 = 0 Vdc	—	9	14	—	9	14	—	9	14	
	INHIBIT PIN 12 = 0 Vdc	—	35	70	—	35	70	—	35	70	
OUTPUT VOLTAGE	FULL LOAD	4.95	5.00	5.05	11.88	12.00	12.12	14.85	15.00	15.15	Vdc
OUTPUT CURRENT ²	V _{IN} = 19 to 40 Vdc T _c = -55°C to +100°C	0	—	16	0	—	7.5	0	—	6.67	A
OUTPUT POWER ²	V _{IN} = 19 to 40 Vdc T _c = -55°C to +100°C	—	—	80	—	—	90	0	—	100	W
EFFICIENCY	FULL LOAD	77	80	—	83	86	—	84	87	—	%
LINE REGULATION	FULL LOAD, V _{IN} = 19 to 40 Vdc T _c = -55°C to +100°C	—	0	20	—	0	20	—	0	20	mV
LOAD REGULATION	NO LOAD TO FULL T _c = -55°C to +100°C	—	0	20	—	0	20	—	0	20	mV
OUTPUT RIPPLE VOLTAGE	FULL LOAD, 10kHz-2MHz T _c = 25°C T _c = -55°C to +100°C	—	15	35	—	30	75	—	30	85	mVp-p
		—	30	75	—	45	125	—	45	150	
INPUT RIPPLE CURRENT	FULL LOAD, 10kHz-10MHz T _c = -55°C to +100°C	—	15	50	—	15	50	—	15	50	mAp-p
LOAD FAULT POWER DISSIPATION ³	SHORT CIRCUIT	—	15	20	—	15	20	—	15	20	W
LOAD FAULT RECOVERY ⁴	SHORT CIRCUIT TO FULL LOAD T _c = -55°C to +100°C	—	1.5	4	—	1.5	4	—	1.5	4	mS
STEP LOAD RESPONSE, TRANSIENT, RECOVERY ⁵	T _c = -55°C to +100°C P _{OUT} = 50% ↔ 100% P _{OUT} = 50% ↔ 100%	—	350	450	—	450	700	—	450	700	mVpk mS
		—	1.5	3.0	—	1.5	3.0	—	1.5	3.0	
STEP LINE RESPONSE, TRANSIENT ³ , RECOVERY ⁴	T _c = -55°C to +100°C 16 to 40 Vdc ↔ 40 to 19 Vdc 16 to 40 Vdc ↔ 40 to 19 Vdc	—	250	400	—	250	400	—	250	400	mVpk μS
		—	200	300	—	200	300	—	200	300	
STARTUP DELAY OVERSHOOT	T _c = -55°C to +100°C FULL LOAD FULL LOAD	—	3.5	6.0	—	3.5	6.0	—	3.5	6.0	mS mVpk
		—	0	25	—	0	50	—	0	50	

Notes:

1 80V limit rated for up to 50mS. Unit will shut down above ≈45V but will be undamaged and will restart when voltage drops into normal range.

2 Derate output power/current linearly from 100% at +100°C to 0 at +135°C.

3 Indefinite short circuit protection not guaranteed above 100°C (case).

4 Recovery time is measured from application of the transient to point at which V_{OUT} is within 1% of final value.

5 Transition time > 10 μS.

DUAL OUTPUT MODELS: $T_c = 25^\circ\text{C}$, $V_{IN} = 28\text{ Vdc}$ unless otherwise specified.

PARAMETER	CONDITION	MFLHP2805D			MFLHP2812D			MFLHP2815D			UNITS	
		MIN	TYP	MAX	MIN	TYP	MAX	MIN	TYP	MAX		
INPUT VOLTAGE	$T_c = -55^\circ\text{C}$ to $+100^\circ\text{C}$ NO LOAD TO FULL NORMAL TRANSIENT ¹	19	28	40	19	28	40	19	28	40	Vdc	
INPUT CURRENT	NO LOAD	—	50	120	—	50	100	—	50	100	mA	
	FULL LOAD	—	3571	—	—	3782	—	—	4153	—		
	INHIBIT $P_{IN} 4 = 0\text{ Vdc}$ INHIBIT $P_{IN} 12 = 0\text{ Vdc}$	—	9	14	—	9	14	—	9	14		
OUTPUT VOLTAGE	FULL LOAD	$+V_{OUT}$	4.95	5.00	5.05	11.88	12.00	12.12	14.85	15.00	15.15	Vdc
		$-V_{OUT}$	4.92	5.00	5.08	11.82	12.00	12.18	14.77	15.00	15.23	
OUTPUT CURRENT ^{2, 3}	$V_{IN} = 19$ to 40 Vdc , $T_c = -55^\circ\text{C}$ to $+100^\circ\text{C}$ EACH OUTPUT TOTAL OUTPUT		0	—	11.2	0	—	5.3	0	—	4.67	A
			0	—	16.0	0	—	7.5	0	—	6.67	
OUTPUT POWER ^{2, 3}	$V_{IN} = 19$ to 40 Vdc , $T_c = -55^\circ\text{C}$ to $+100^\circ\text{C}$ EACH OUTPUT TOTAL OUTPUT		0	—	56	0	—	63	0	—	70	W
			0	—	80	0	—	90	0	—	100	
EFFICIENCY	$V_{IN} = 28$, FULL LOAD	77	80	—	83	86	—	84	87	—	%	
LINE REGULATION	FULL LOAD $V_{IN} = 19$ to 40 Vdc $T_c = -55^\circ\text{C}$ to $+100^\circ\text{C}$	$+V_{OUT}$	—	0	50	—	0	50	—	0	50	mV
		$-V_{OUT}$	—	25	100	—	25	100	—	25	100	
LOAD REGULATION	NO LOAD TO FULL $T_c = -55^\circ\text{C}$ to $+100^\circ\text{C}$	$+V_{OUT}$	—	0	50	—	10	100	—	10	100	mV
		$-V_{OUT}$	—	25	100	—	50	200	—	50	200	
CROSS REGULATION ⁴ (EFFECT ON $-V_{OUT}$)	$+P_{OUT} = 30\%$ TO 70% $-P_{OUT} = 70\%$ TO 30% $-P_{OUT} = 10\%$ TO 50% $+P_{OUT} = 50\%$		—	6	8	—	2	4	—	2	4	%
			—	3	6	—	2	4	—	2	4	
OUTPUT RIPPLE VOLTAGE	FULL LOAD, 10kHz-2MHz $T_c = -55^\circ\text{C}$ to $+100^\circ\text{C}$	$+V_{OUT}$	—	25	125	—	50	150	—	50	200	mVp-p
		$-V_{OUT}$	—	25	125	—	50	150	—	50	200	
INPUT RIPPLE CURRENT	FULL LOAD, 10 kHz – 10 MHz $T_c = -55^\circ\text{C}$ to $+100^\circ\text{C}$	—	15	50	—	15	50	—	15	50	mA p-p	
LOAD FAULT POWER DISSIPATION ⁵	SHORT CIRCUIT	—	15	20	—	15	20	—	15	20	W	
LOAD FAULT RECOVERY ⁶	SHORT TO FULL LOAD	—	1.5	4.0	—	1.5	4.0	—	1.5	4.0	mS	
STEP LOAD RESPONSE, TRANSIENT RECOVERY ⁶	$T_c = -55^\circ\text{C}$ to $+100^\circ\text{C}$ 50% ↔ 100% 100% ↔ 50%	$\pm V_{OUT}$	—	350	450	—	450	700	—	450	700	mVpk mS
			—	1.5	3.0	—	1.5	3.0	—	1.5	3.0	
STEP LINE RESPONSE, TRANSIENT RECOVERY ⁶	$T_c = -55^\circ\text{C}$ to $+100^\circ\text{C}$ 19 ↔ 40 Vdc 19 ↔ 40 Vdc		—	250	400	—	250	400	—	250	400	mVpk μS
			—	200	300	—	200	300	—	200	300	
STARTUP DELAY OVERSHOOT	$T_c = -55^\circ\text{C}$ to $+100^\circ\text{C}$ FULL LOAD FULL LOAD		—	3.5	6.0	—	3.5	6.0	—	3.5	6.0	mS mVpk
			—	0	25	—	0	50	—	0	50	

Notes:

- 80V limit rated for up to 50mS. Unit will shut down above $\approx 45\text{V}$ but will be undamaged and will restart when voltage drops into normal range.
- Derate output power/current linearly from 100% at $+100^\circ\text{C}$ to 0 at $+135^\circ\text{C}$.
- Up to 70% of the total output power is available from either output providing the opposite is simultaneously carrying 30% of the total output power.
- Shows regulation effect on the minus output during the defined cross loading conditions (see Figure 5).
- Indefinite short circuit protection not guaranteed above 100°C (case).
- Recovery time is measured from application of the transient to point at which V_{OUT} is within 1% of final value.
- Transition time $> 10\ \mu\text{S}$.



interpoint
A CRANE CO. COMPANY

MFLHP SERIES DC/DC CONVERTERS

North America: Tel. (800) 822-8782, (425) 882-3100 Fax (425) 882-1990

International: Tel. +44-1252-815511 Fax +44-1252-815577

TYPICAL PERFORMANCE CURVES

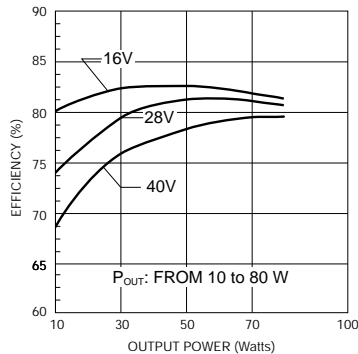

MFLHP2805S & MFLHP2805D
EFFICIENCY VS. LINE & LOAD

Figure 1

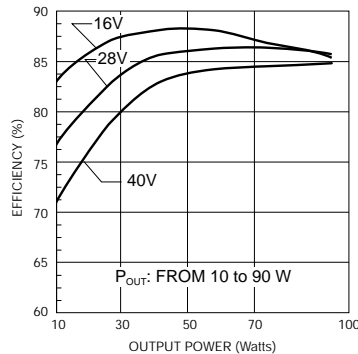

MFLHP2812S & MFLHP2812D
EFFICIENCY VS. LINE & LOAD

Figure 2

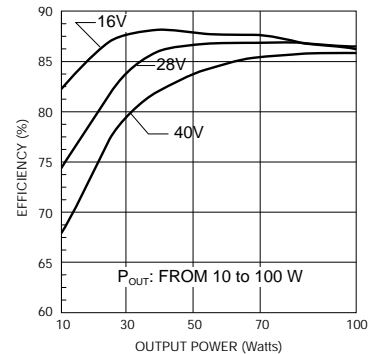

MFLHP2815S & MFLHP2815D
EFFICIENCY VS. LINE & LOAD

Figure 3

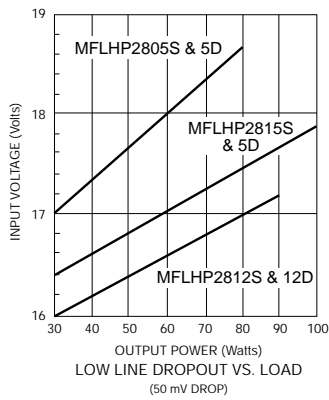

LOW LINE DROPOUT VS. LOAD
(50 mV DROP)

Figure 4

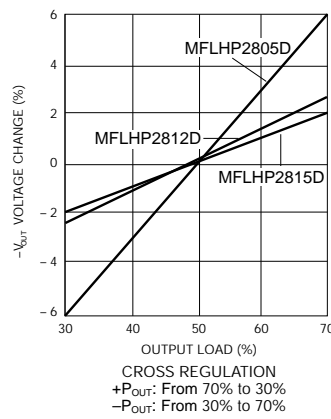

CROSS REGULATION
+P_{OUT}: From 70% to 30%
-P_{OUT}: From 30% to 70%

Figure 5

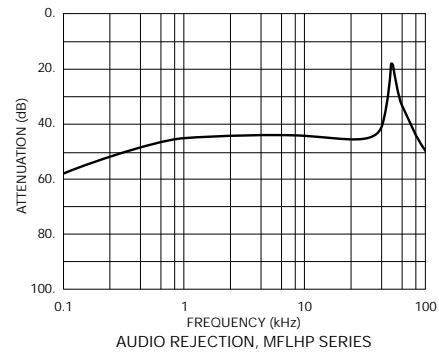

AUDIO REJECTION, MFLHP SERIES

Figure 6

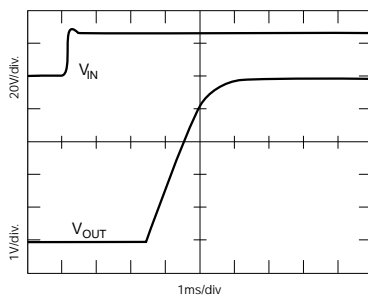

TURN-ON INTO NO LOAD, MFLHP2805S

Figure 7

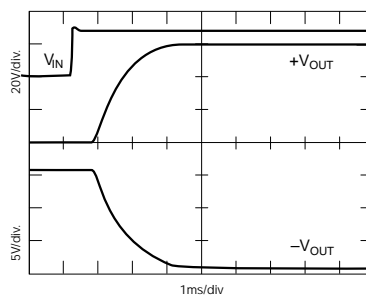

TURN-ON INTO NO LOAD, MFLHP2815D

Figure 8

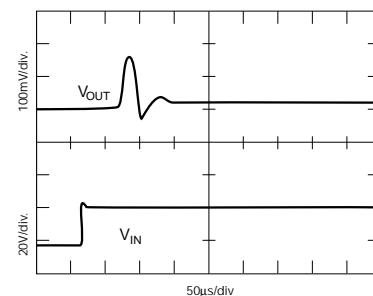

INPUT LINE TRANSIENT RESPONSE
(19V TO 40V), MFLHP2805S

Figure 9



interpoint
A CRANE CO. COMPANY

MFLHP SERIES DC/DC CONVERTERS

North America: Tel. (800) 822-8782, (425) 882-3100 Fax (425) 882-1990

International: Tel. +44-1252-815511 Fax +44-1252-815577

TYPICAL PERFORMANCE CURVES

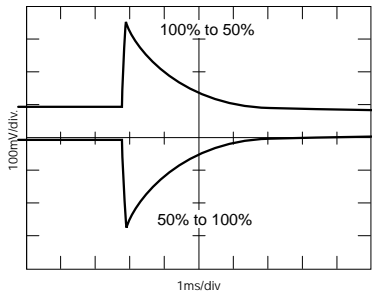

LOAD TRANSIENT RESPONSE
(50% ↔ 100%), MFLHP2805S

Figure 10

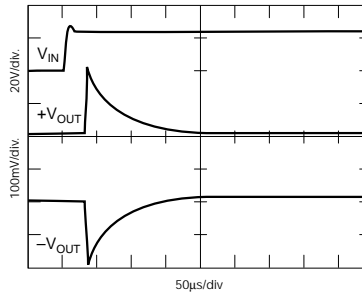

INPUT LINE TRANSIENT RESPONSE
(19V TO 40V), MFLHP2815D

Figure 11

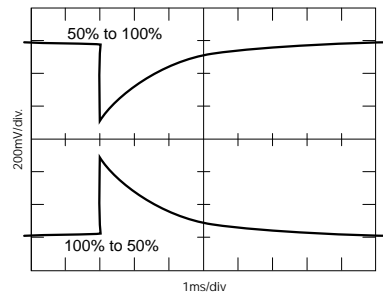

+V_O LOAD TRANSIENT RESPONSE
(50% ↔ 100%), MFLHP2815D

Figure 12

CONNECTION FOR PARALLEL OPERATION

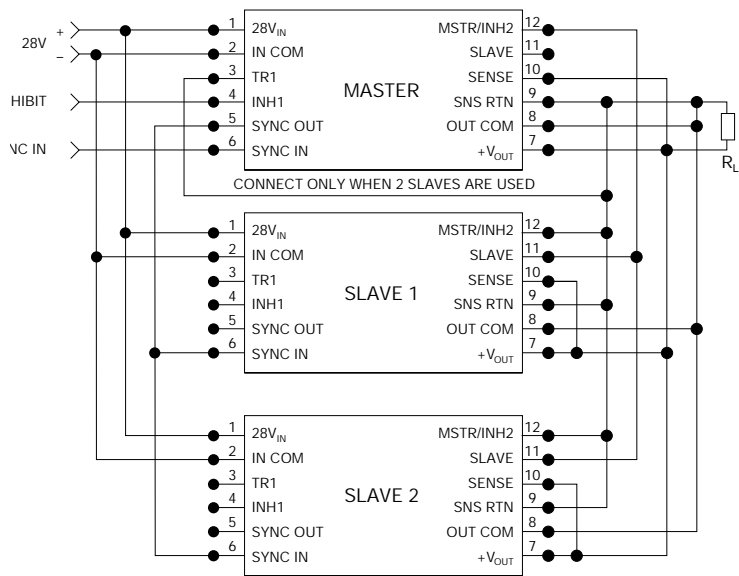

PARALLEL CONNECTION
(APPLICABLE TO SINGLE OUTPUT MODELS ONLY)

Figure B



A CRANE CO. COMPANY

MFLHP SERIES DC/DC CONVERTERS

North America: Tel. (800) 822-8782, (425) 882-3100 Fax (425) 882-1990

International: Tel. +44-1252-815511 Fax +44-1252-815577

SCREENING OPTIONS*

	/ES		/ES
PRE-CAP INSPECTION Method 2017, 2032	•	FINAL VISUAL INSPECTION Method 2009	•
TEMPERATURE CYCLE (10 times) Method 1010, -55 to +125°C	•	FINAL ELECTRICAL TEST 25°C case (typ.)	•
CONSTANT ACCELERATION Method 2001, 500 g	•	HERMETICITY TESTING Fine Leak, Method 1014, Cond. A Gross Leak, Method 1014, Cond. C	•
BURN-IN 96 hours at 100°C case (typ.)	•		•

*All methods and conditions referenced to MIL-STD-883.

To order model options, enter screening designation as suffix to the part number. For example, MFLHP 2805S/ES. On unscreened parts, the screening code block is marked "01"; on /ES screened parts, it is marked /ES or "02".

METAL HERMETIC PACKAGE:

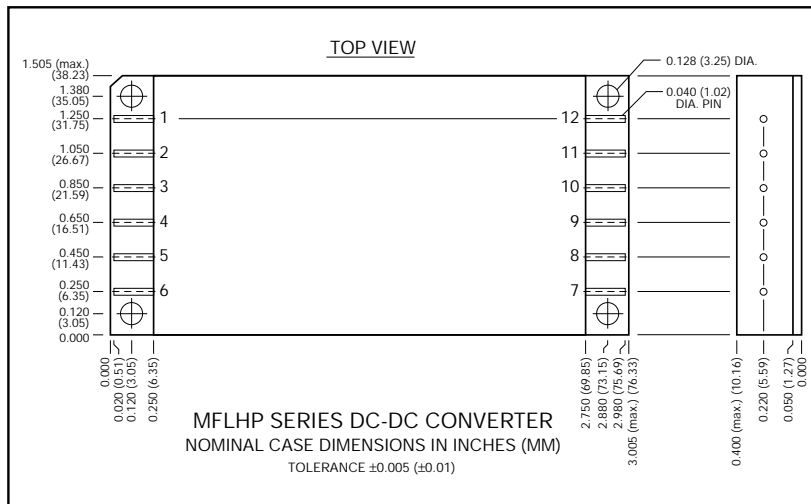

DESIGNATION	MFLHP2805S	MFLHP2805D
	MFLHP2812S	MFLHP2812D
	MFLHP2815S	MFLHP2815D
	PIN NO.	PIN NO.
Positive input	1	1
Input common	2	2
Triple	3	3
Inhibit 1	4	4
Sync out	5	5
Sync in	6	6
Positive output	7	7
Output common	8	8
Negative output	-	9
Sense return	9	-
Positive sense	10	-
Slave to master	11	11
Master to slave/inhibit 2	12	12

PIN 6 SHOULD BE CONNECTED TO INPUT COMMON IF EXTERNAL SYNC IS NOT USED.

CAUTION: Heat from reflow or wave soldering may damage this part. Solder pins individually with heat application NOT exceeding 300°C for 10 seconds per pin.

PACKAGE NOTES:

MFLHP Series packages use gold-plated cold rolled steel cases, nickel-plated Kovar covers and are seam welded.

PACKAGE OPTIONS:

A variety of package options are available for the MFL, MFLHP, MHP, FME, and FMD. The packages use gold-plated cold rolled steel headers, nickel-plated Kovar covers, and are seam welded for a hermetic seal. The standard package has flanges on the lead-end with straight leads. Package V has lead-end flanges with leads that extend beyond the mounting flanges and bend down for through-hole mounting. Packages W, Y, and Z have tab flanges on the non-lead sides and offer three lead options:

Straight leads — Package Y
 Leads bent up — Package W
 Leads bent down — Package Z

TO ORDER:

Standard Package:

Use the standard model number to order.
 Standard screening example: MFL2805D.
 Optional environmental screening example: MFL2805D/ES

Packages V, W, Y or Z:

To order one of the options, insert the case letter at the end of the model number but before the screening code.
 Standard screening example: MFL2805DV
 Optional environmental screening example: MFL2805DV/ES

CAUTION: Heat from reflow or wave soldering may cause damage. Solder leads individually with heat application NOT exceeding 300°C for 10 seconds per lead.

STANDARD PACKAGE (TOP VIEW)

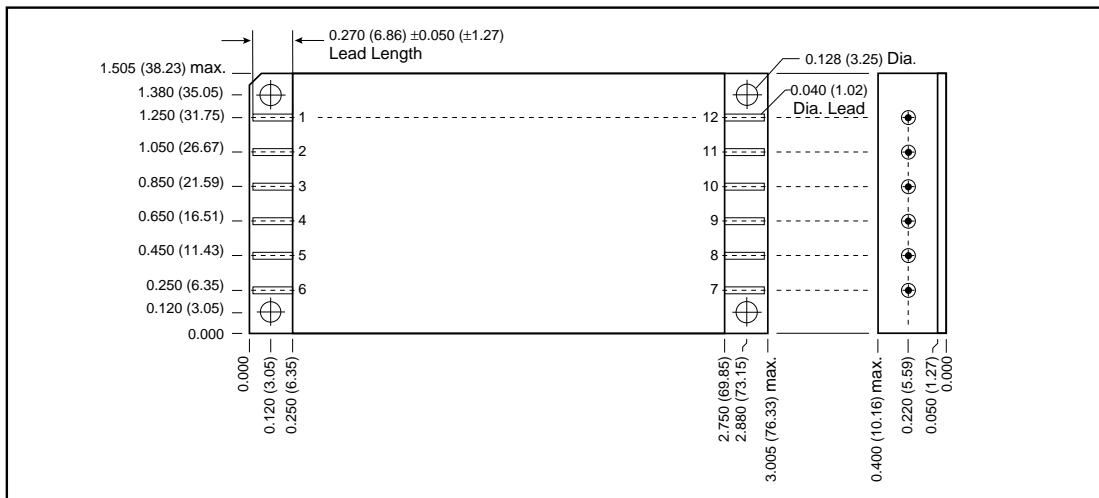

FLANGE ON LEAD END — PACKAGE V (TOP VIEW)

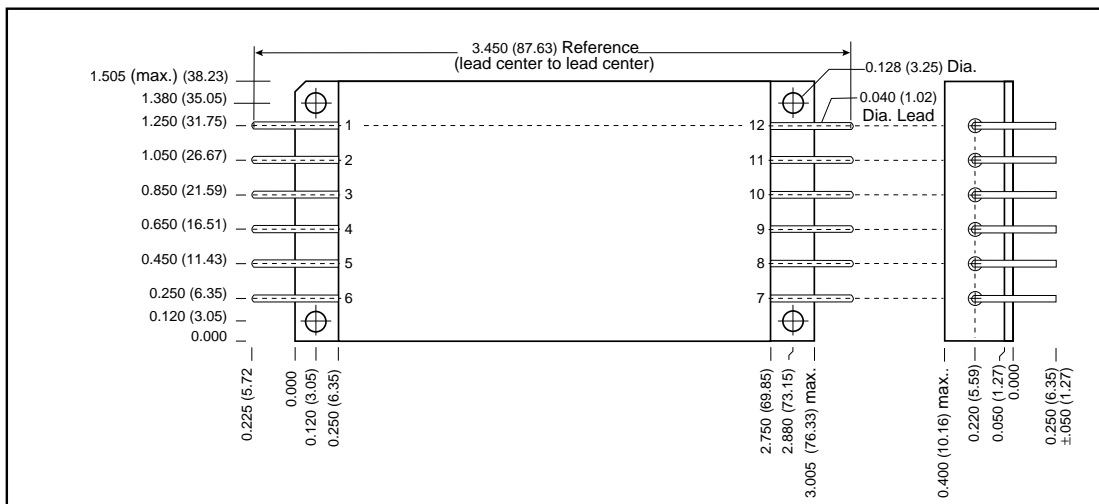

NOMINAL CASE DIMENSIONS IN INCHES (MM)
 Tolerance ±0.005 (±0.13) for three decimal places,
 ±0.01 (±0.3) for two decimal places.

TABS, NON-LEAD SIDE — PACKAGE W, Y, OR Z (TOP VIEW)

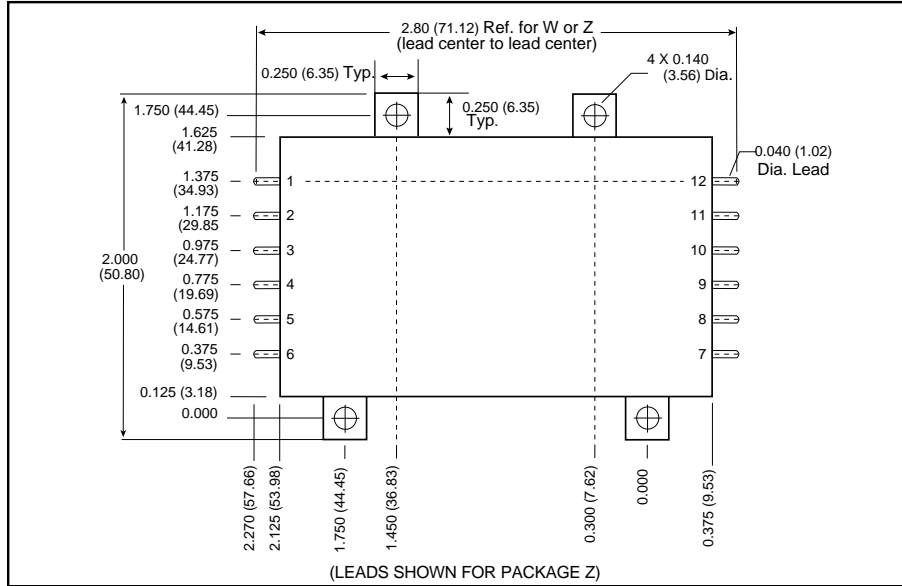

LEAD OPTIONS FOR TAB PACKAGES SHOWN ABOVE (LEAD-END VIEW)

